

SHANGHAI CIPHY INDUSTRY LTD.,CO.

ANSI CLASS 150

CARBON STEEL OR STAINLESS STEEL

PISTON VALVE BOLTED BONNET DESIGN

MODEL NO: SHAXRF-000



PISTON VALVE PRODUCT'S SIZE:

PRESSURE GRADE	FROM	TO
CLASS 150	1/2"	8"
CLASS 300	1/2"	8"

DESIGN DESCRIPTION:

- * BOLTED BONNET AND WELDING BONNET;
- * WELDING SEAT; INTEGRAL SEATS;
- * HANDWHEEL OPERATOR;
- * AVAILABLE WITH GEAR OPERATOR;
- * FLANGED ENDS OR BUTT-WELDING ENDS;
- * RISING FLANGE OR RING TYPE JOINT.

WORKING PRESSURE AND TEMPERATURE

WORKING TEMPERATURE		
MATERIAL	CELSIUR SCALE	FAHRENHEIT
CARBON STEEL	-290C~4250C	60F~8220F
STAINLESS STEEL	-400C~5500C	150F~10470F

GENERAL DESIGN SPECIFICATIONS:

ITEM	CLASS 150
MANUFACTURE	DIN 3356
FACE TO FACE	DIN 3202 F1
END FLANGE	ANSI B16.5
INSPECTION AND TEST	API 598

TEST PRESSURE TO API598:

CLASS	SHELL (WATER)		SEAT (WATER)		SEAT (AIR)		BACK SEAT(WATER)	
150	3.1MPA	450PSI	2.2MPA	315PSI	0.6MPA	80PSI	3.1MPA	450PSI
300	7.8MPA	1125PSI	5.6MPA	815PSI	0.6MPA	80PSI	7.8MPA	1125PSI

TRIMS SPECITIED DUE TO TABLE 3:

DISC SEAT SURFACE PART NO.3	BODY SEAT SURFACE PART NO.2	STEM PART NO.9	SEAL RING PART NO.2(B)
F6	F6	F6	PTFE OR GRAPHITE
STELLITE	STELILITE	F6	
F6	STELILITE	F6	
F304	F304	F304	
F316	F316	F316	
MONEL	MONEL	MONEL	
ALLOY 20	ALLOY 20	ALLOY 20	
HASTELLOY B	HASTELLOY B	HASTELLOY B	
BRONZE	BRONZE	BRONZE	
CF8	R-PTFE(INSERT)	S.S.	
OTHER MATERIALS ARE AVAILABLE UPON REQUEST.			

PARTS AND MATERIAL (ASTM)

NO	PARTS NAME	MATERIAL									
1	BODY	A216WCB	A352LCB	A217WC1	A217WC5	A217WC6	A351CF8	A351CF8M	A351CF3	A351CF3M	
4	SEAT RIONG	DUCTILE IRON						A351CF8	A351CF8M	A351CF3	A351CF3M
5	GASKET	REINFORCED FLAT GRAPHITE,OR SS SPIREAL WOUND W/GRAPHITE									
6	BONNET	A216WCB	A352LCB	A217WC1	A217WC5	A217WC6	A351CF8	A351CF8M	A351CF3	A351CF3M	
7	BONNET BOLT	A193B7	A320L7	A193B7	A193B16	A193B16	A193B8	A193B8	A193B8	A193B8	
8	BONNET BOLT NUT	A1942H	A1944	A1942H	A1944	A1944	A1948	A1948	A1948	A1948	
10	STEM NUT	A439-D2 OR A276-410									
11	HANDWHEEL	DUCTILE IRON									
12	H.W.LOCK NUT	STEEL									

OTHER MATERIALS ARE AVAILABLE UPON REQUEST.

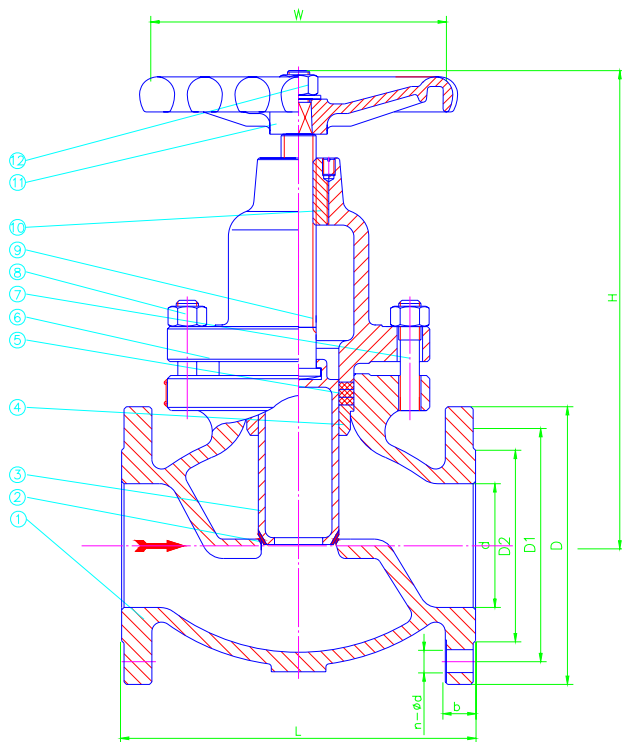

A type

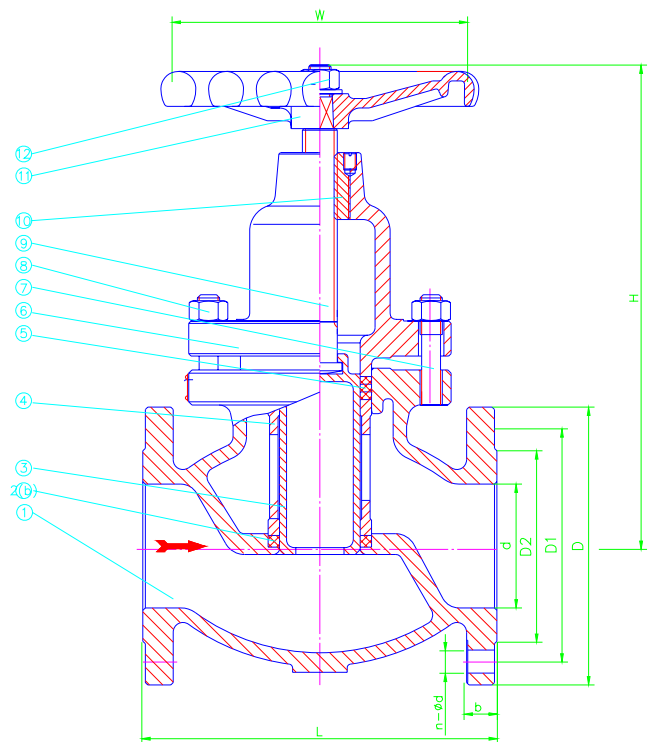

B type

DIMENSIONS LIST(UNIT:inch):**CLASS 150 GLOBE VALVE FLANGE END AND WLEDING END**

DN	NPS	F(mm)	L	LJ	D	D1	D2	b	Z*Φd	W	H(OPEN)(mm)	Wt(kg)
15	1/2	2.1	4-1/4	-	3-1/2	2-3/8	1-3/8	-	4*5/8	4	115	3.5
20	3/4	2.1	4-5/8	-	3-7/8	2-3/4	1-11/16	-	4*5/8	4	135	3.9
25	1	2.1	5	-	4-1/4	3-1/8	2	7/16	4*5/8	4-3/4	155	5.8
40	1-1/2	2.1	6-1/2	-	5	3-7/8	2-7/8	9/16	4*5/8	5-1/4	190	10.8
50	2	2.1	8	-	6	4-3/4	3-5/8	5/8	4*3/4	7-7/8	205	20
65	2-1/2	2.1	8-1/2	-	7	5-1/2	4-1/8	11/16	4*3/4	9-7/8	245	32
80	3	2.1	9-1/2	-	7-1/2	6	5	3/4	4*3/4	11	285	42
100	4	2.1	11-1/2	-	9	7-1/2	6-3/16	15/16	8*3/4	11-3/4	320	64
150	6	2.1	16	-	11	9-1/2	8-1/2	1	8*7/8	13-3/4	410	114
200	8	2.1	19-1/2	-	13-1/2	11-3/4	10-5/8	1-1/8	8*7/8	15-3/4	530	186

CLASS 300 GLOBE VALVE FLANGE END AND WLEDING END

DN	NPS	F(mm)	L	LJ	D	D1	D2	b	Z*Φd	W	H(OPEN)(mm)	Wt(kg)
15	1/2	2.1	6	6-7/16	3-3/4	2-5/8	1-3/8	9/16	4*5/8	4	152	3.7
20	3/4	2.1	7	7-1/2	4-5/8	3-1/4	1-11/16	5/8	4*3/4	4-3/4	178	5.3
25	1	2.1	8	8-1/2	4-7/8	3-1/2	2	11/16	4*3/4	5	203	7.3
40	1-1/2	2.1	9	9-1/2	6-1/8	4-1/2	2-7/8	13/16	4*7/8	6-5/8	229	15.4
50	2	2.1	10-1/2	11-1/8	6-1/2	5	3-5/8	7/8	8*3/4	7-7/8	267	26
65	2-1/2	2.1	11-1/2	12-1/8	7-1/2	5-7/8	4-1/8	1	8*7/8	7-7/8	292	40
80	3	2.1	12-1/2	13-1/8	8-1/4	6-5/8	5	1-1/8	8*7/8	11	318	50
100	4	2.1	14	14-5/8	10	7-7/8	6-3/16	1-1/4	8*7/8	13-3/4	356	90
150	6	2.1	17-1/2	18-1/8	12-1/2	10-5/8	8-1/2	1-7/16	12*7/8	15-3/4	444	160
200	8	2.1	22	22-5/8	15	13	10-5/8	1-5/8	12*1	17-3/4	810	290

*** We hereby reserve the rights of any alternative dimension that would help to improve our valve's quality and working efficiency**



SHANGHAI CIPHY INDUSTRY CO.,LTD

Rm. 11D, Jinghong Building, No.508

Yishan Rd., Shanghai, P.R.China

TEL:+86-21-6441 4886

FAX:+86-21-6441 4889

HTTP://WWW.CIPHY.CN

CIPHY@CIPHY.COM

COPYRIGHT©2004-[CIPHY]

ALL RIGHTS RESERVED.