

SHANGHAI CIPHY INDUSTRY CO.,LTD.

ANSI 1000WOG WITH MOUNTING PAD

CARBON STEEL OR STAINLESS STEEL

2-PC BALL VALVE BOLTED CAP DESIGN

MODEL NO: SLAXTH-2P-MT



BALL VALVE PRODUCT'S SIZE:

PRESSURE GRADE	FROM	TO
ANSI 1000WOG	1/4"	2"

DESIGN DESCRIPTION:

- * BOLTED CAP, 2-PC
- * INVESTMENT CASTING BODY
- * ISO 5211 MOUNT PAD
- * BLOW-OUT PROOF STEM DESIGN
- * CONNCTRION: THREADED ENDS
- * THREAD TYPE(ANSI,DIN,BS)

WORKING PRESSURE AND TEMPERATURE

WORKING TEMPERATURE		
MATERIAL	CELSIUR SCALE	FAHRENHEIT
CARBON STEEL	-29°C~200°C	6°F~392°F
STAINLESS STEEL	-40°C~200°C	15°F~392°F

GENERAL DESIGN SPECIFICATIONS:

ITEM	ANSI 1000WOG
MANUFACTURE	FACTORY STANDARDS
PRESSURE-TEMPERATURE RATINGS	ANSI B16.34
END THREAD	NPT, DIN, BSP/BSPT, JIS
INSPECTION AND TEST	API 598

TEST PRESSURE TO API 598

ANSI	SHELL (WATER)		SEAT (WATER)		SEAT (AIR)	
1000	10.5MPA	1500PSI	7.7MPA	1100PSI	0.6MPA	80PSI

PARTS AND MATERIAL (ASTM)

NO.	PART NAME	MATERIAL
1	BODY	ASTM A216-WCB, A351-CF8/CF8M
2	END CAP	ASTM A216-WCB, A351-CF8/CF8M
3	SOLID BALL	ASTM A351-CF8/CF8M
4	SEAT	PTFE
5	STEM	SS316/SS304
6	STEM SEAL	PTFE
7	GASKET	PTFE
8	THRUST WASHER	PTFE
9	STEM PACKING	PTFE
10	GLAND	SS316/SS304
11	BELLEVILLE WASHER	SS301
12	GLAND NUT	SS 304
13	HANDLE NUT	SS 304
14	HANDLE	CARBON STELL/SS 304
15	HANDLE PLATIC	PLATIC

OTHER MATERIALS ARE AVAILABLE UPON REQUEST.

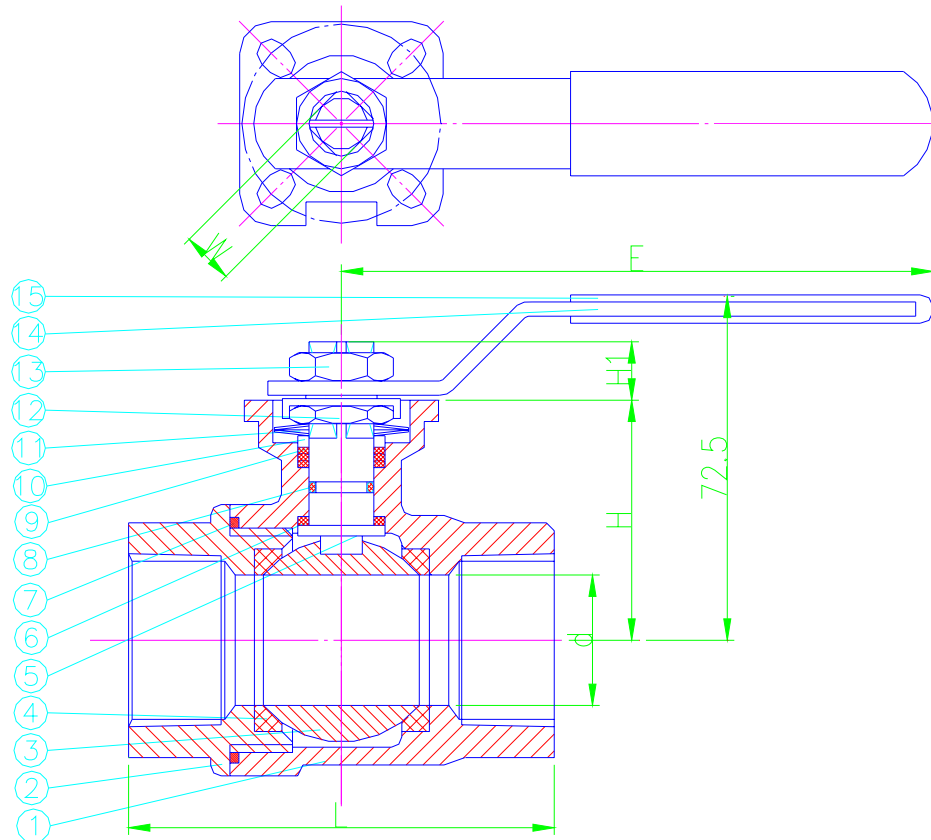

DIMENSIONS LIST(UNIT:MM):

DN	Size	d	L	H	H1	H2	W	E	ISO5211
6	1/4"	11	55	40	7	72	9	139	F03/F04
10	3/8"	13	55	40	7	72	9	139	F03/F04
15	1/2"	15	70	40	7	72	9	139	F03/F04
20	3/4"	20	80	40	9	75	9	139	F03/F04
25	1"	25	90	52	9.5	77	9	165	F04/F05
32	1-1/4"	32	102	58	11.5	95	11	165	F04/F05
40	1-1/2"	40	110	68	11.5	101	11	215	F05/F07
50	2"	50	130	77	15	125	11	215	F05/F07

*** We hereby reserve the rights of any alternative dimension that would help to improve our valve's quality and working efficiency**



SHANGHAI CIPHY INDUSTRY CO.,LTD
7G-1 Building, N0.515 Yishan Rd.
Shanghai, China
TEL:+86-21-5497 5962
FAX:+86-21-5497 5963
HTTP://WWW.CIPHY.CN
CIPHY@CIPHY.COM
COPYRIGHT©2004-[CIPHY]
ALL RIGHTS RESERVED.