

# SHANGHAI CIPHY INDUSTRY CO.,LTD.

## ANSI 1000WOG WITH DIRECT MOUNTING PAD

### CARBON STEEL OR STAINLESS STEEL

### 2-PC BALL VALVE BOLTED CAP DESIGN

**MODEL NO: SLAXTH-2P-DM**



#### **BALL VALVE PRODUCT'S SIZE:**

PRESSURE GRADE	FROM	TO
ANSI 1000WOG	1/4"	3"

#### **DESIGN DESCRIPTION:**

- \* BOLTED CAP, 2-PC
- \* INVESTMENT CASTING BODY
- \* ISO 5211 DIRECT MOUNT PAD
- \* BLOW-OUT PROOF STEM DESIGN
- \* CONNCTRION: THREADED ENDS
- \* THREAD TYPE(ANSI,DIN,BS)

#### **WORKING PRESSURE AND TEMPERATURE**

WORKING TEMPERATURE		
MATERIAL	CELSIUR SCALE	FAHRENHEIT
CARBON STEEL	-29°C~200°C	6°F~392°F
STAINLESS STEEL	-40°C~200°C	15°F~392°F

#### **GENERAL DESIGN SPECIFICATIONS:**

ITEM	ANSI 1000WOG
MANUFACTURE	FACTORY STANDARDS
PRESSURE-TEMPERATURE RATINGS	ANSI B16.34
END THREAD	NPT, DIN, BSP/BSPT, JIS
INSPECTION AND TEST	API 598

#### **TEST PRESSURE TO API 598**

ANSI	SHELL (WATER)		SEAT (WATER)		SEAT (AIR)	
1000	10.5MPA	1500PSI	7.7MPA	1100PSI	0.6MPA	80PSI

#### **PARTS AND MATERIAL (ASTM)**

NO.	PART NAME	MATERIAL
1	BODY	ASTM A216-WCB, A351-CF8/CF8M
2	END CAP	ASTM A216-WCB, A351-CF8/CF8M
3	SOLID BALL	ASTM A351-CF8/CF8M
4	SEAT	PTFE
5	STEM	SS316/SS304
6	STEM SEAL	PTFE
7	GASKET	PTFE
8	THRUST WASHER	PTFE
9	STEM PACKING	PTFE
10	GLAND	SS316/SS304
11	BELLEVILLE WASHER	SS301
12	GLAND NUT	SS 304
13	HANDLE NUT	SS 304
14	HANDLE	CARBON STEEL/SS 304
15	HANDLE PLATIC	PLATIC

OTHER MATERIALS ARE AVAILABLE UPON REQUEST.

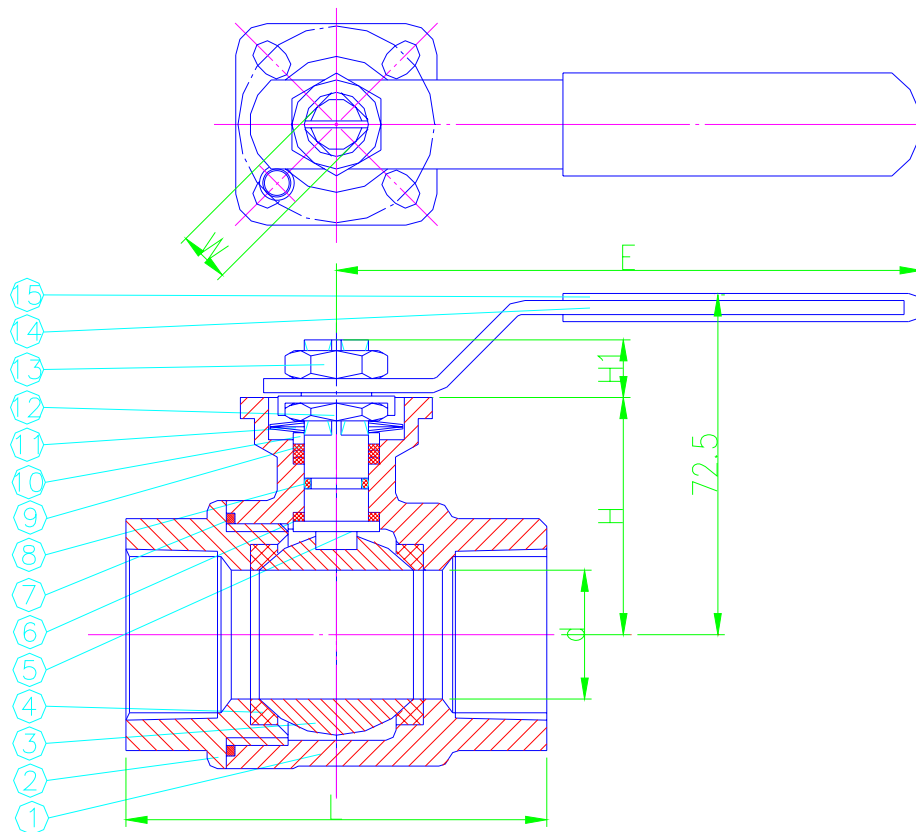

### DIMENSIONS LIST(UNIT:MM):

DN	Size	d	L	H	H1	H2	W	E	ISO5211
6	1/4"	11.5	65	38.6	6.6	73.6	9	139	F03/F04
10	3/8"	12.5	65	38.6	6.6	73.6	9	139	F03/F04
15	1/2"	15	65	38.6	6.6	73.6	9	139	F03/F04
20	3/4"	20	74.5	46.15	7.1	80.15	9	139	F03/F04
25	1"	25	88.5	56.6	10.9	95.4	11	165	F04/F05
32	1-1/4"	32	102	61	10.9	99.8	11	165	F04/F05
40	1-1/2"	38	110	77.5	13.9	126.3	14	215	F05/F07
50	2"	49	125	85.2	13.9	134	14	215	F05/F07
65	2-1/2"	65	160.6	108.7	16.8	166.7	17	263	F07/F10
80	3"	80	178	117.4	18.1	175.4	17	263	F07/F10

**\* We hereby reserve the rights of any alternative dimension that would help to improve our valve's quality and working efficiency**



**SHANGHAI CIPHY INDUSTRY CO.,LTD**  
**7G-1 Building, N0.515 Yishan Rd.**  
**Shanghai, China**  
**TEL:+86-21-5497 5962**  
**FAX:+86-21-5497 5963**  
**HTTP://WWW.CIPHY.CN**  
**CIPHY@CIPHY.COM**  
**COPYRIGHT©2004-[CIPHY]**  
**ALL RIGHTS RESERVED.**